

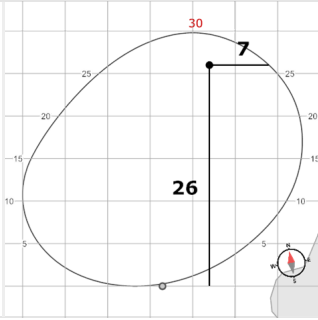

1

+11



2

-2

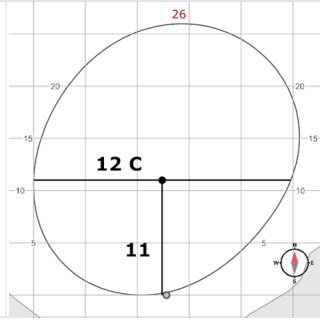

3

-4

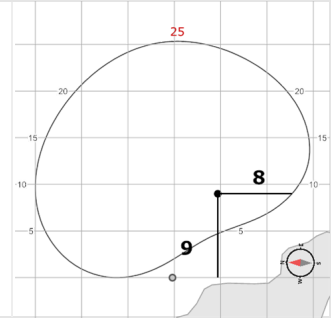

4

+2

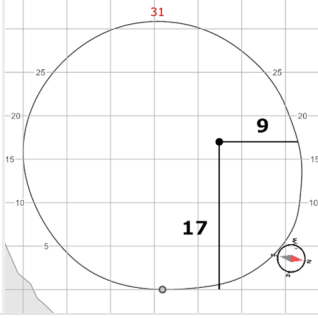

5

+9

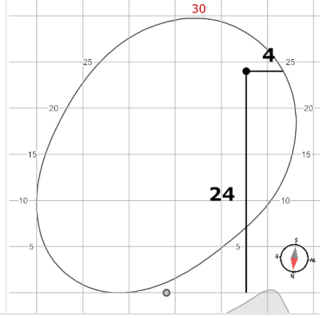

6

-6

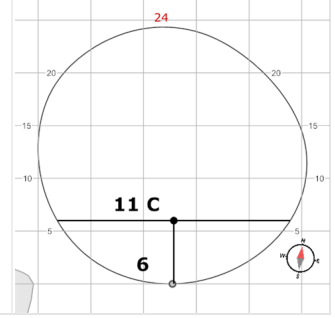

7

+6

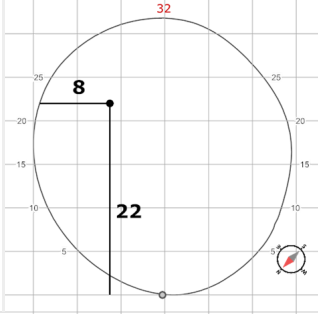

8

+4

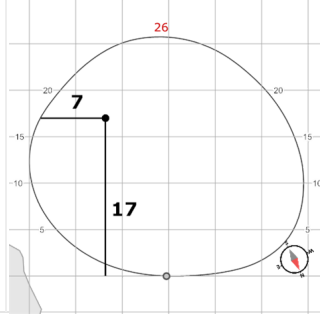

9

-8

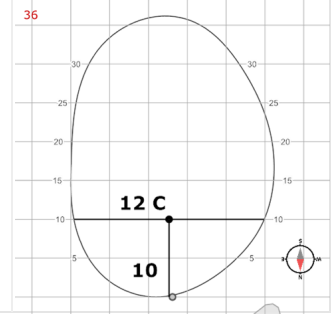

10

+4

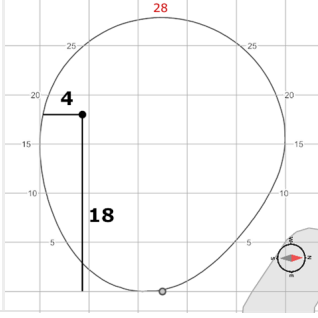

11

+5

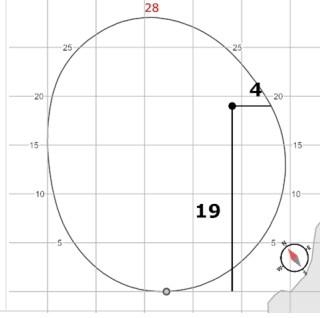

12

-4

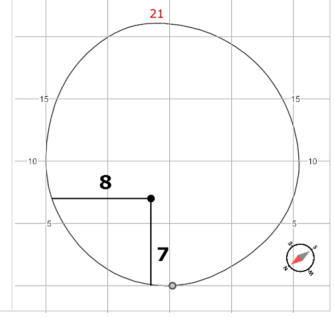

13

+1

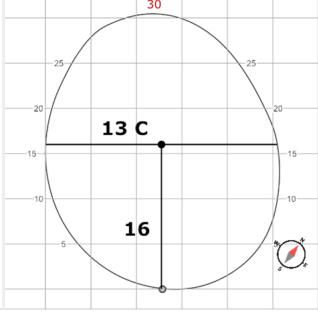

14

+8

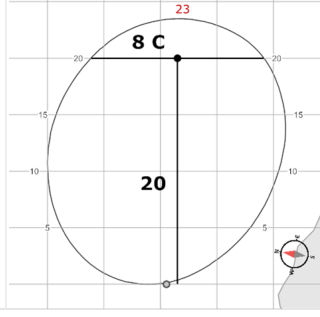

15

-3

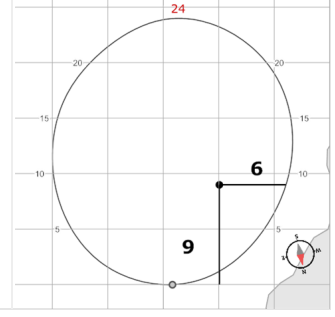

16

+12

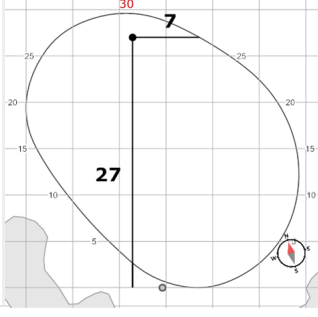

17

+9

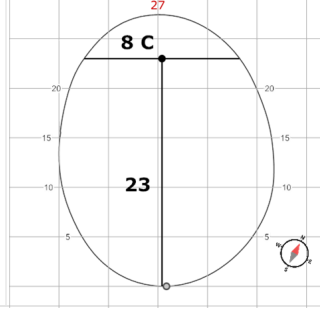

18

-8

